



Rack Mount Chassis RK5000PS-5U



For Endura Modules

C1615M-C (9/06)

Contents

Regulatory Notices	3
Before You Begin	4
Parts List	4
Package Contents	4
Description	5
Front View	5
Back View	6
Installation	7
Mounting a Chassis	7
Installing a Module	8
Installing a Blank Module	9
Installing an Internal Power Supply	10
Service	11
Replacing an Internal Power Supply	11
Replacing a Fan	12
Specifications	14

List of Illustrations

1 Package Components	4
2 RK5000PS-5U Front View	5
3 RK5000PS-5U Back View	6
4 Mounting an RK5000PS-5U into a Rack	7
5 Inserting Cage Nuts	7
6 Endura IP System Module Installation	8
7 Blank Module Installation	9
8 Power Supply Installation	10
9 Fan Baffle Thumbscrews	12
10 Fan Baffle Back Panel	12
11 Fan Screws	13
12 Fan Connector	13

Regulatory Notices

This device complies with Part 15 of the FCC Rules. Operation is subject to the following two conditions: (1) this device may not cause harmful interference, and (2) this device must accept any interference received, including interference that may cause undesired operation.

RADIO AND TELEVISION INTERFERENCE

This equipment has been tested and found to comply with the limits of a Class A digital device, pursuant to Part 15 of the FCC Rules. These limits are designed to provide reasonable protection against harmful interference when the equipment is operated in a commercial environment. This equipment generates, uses, and can radiate radio frequency energy and, if not installed and used in accordance with the instruction manual, may cause harmful interference to radio communications. Operation of this equipment in a residential area is likely to cause harmful interference in which case the user will be required to correct the interference at his own expense.

Changes and Modifications not expressly approved by the manufacturer or registrant of this equipment can void your authority to operate this equipment under Federal Communications Commission's rules.

In order to maintain compliance with FCC regulations shielded cables must be used with this equipment. Operation with non-approved equipment or unshielded cables is likely to result in interference to radio and television reception.

This Class A digital apparatus complies with Canadian ICES-003.

Cet appareil numérique de la classe A est conforme à la norme NMB-003 du Canada.

Before You Begin

Please familiarize yourself with the parts list before installing the unit.

PARTS LIST

Qty	Description
1	RK5000PS-5U rack mount chassis with fan baffle for thermal management
1	USA standard power cord
1	European standard power cord
1	UK standard power cord
10	Thumbscrews for secondary standoffs
4	Screws with washers, 10-32 x 0.750-inch, Phillips, pan head
4	Cage nuts, 10-32
1	RK5000PS-5U Installation manual
1	RK5000PS-5U Safety instructions

PACKAGE CONTENTS

The following diagrams show the contents of the box. When installing the RK5000PS-5U, refer to these diagrams.

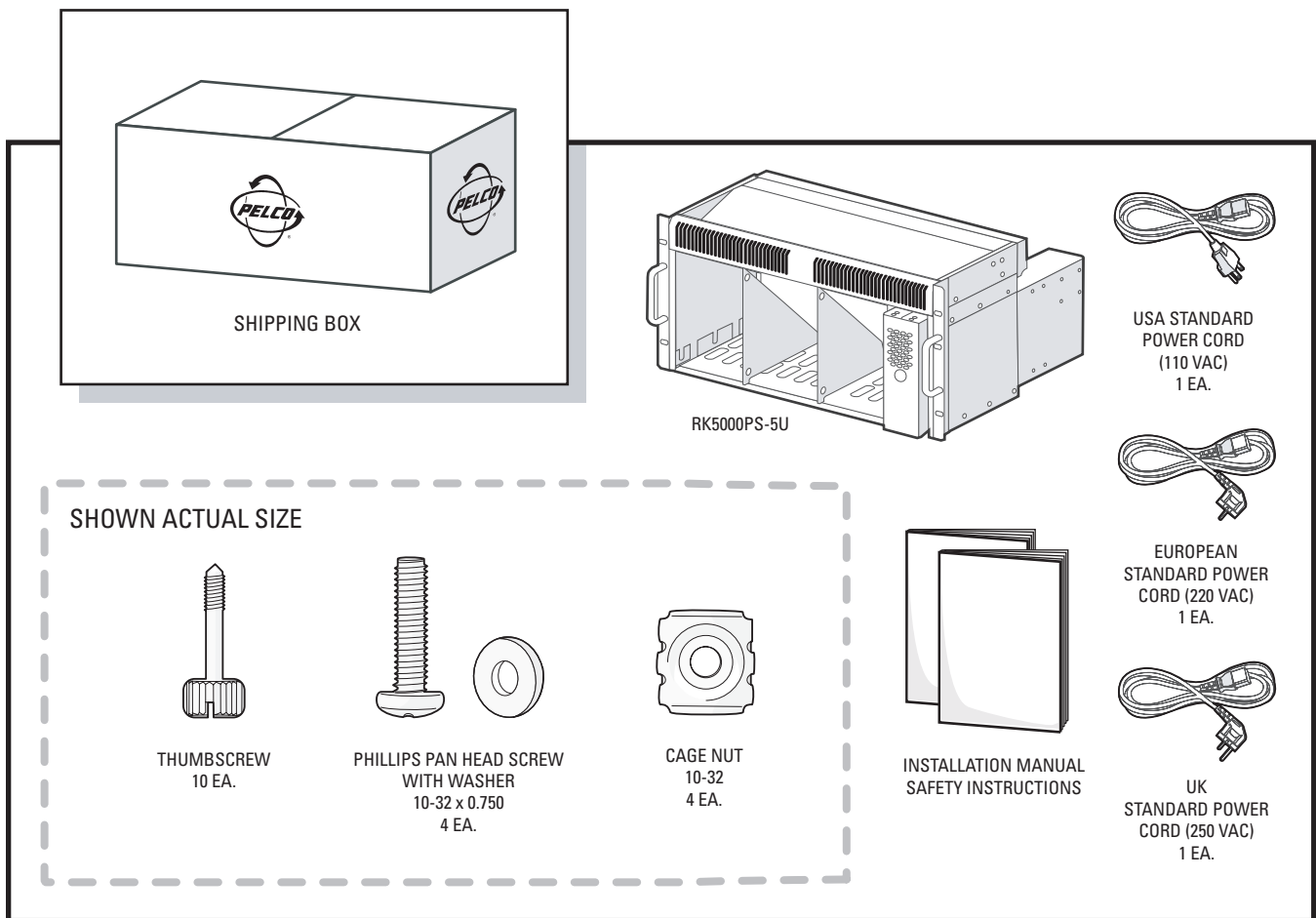

Figure 1. Package Components

Description

The RK5000PS-5U rack mount chassis supports Endura IP system modules. The chassis has 12 slots for single-width modules and 2 slots for an internal, double-width power supply. You can fill the empty slots with single-width blank modules (RK5001B-4U).

The RK5000PS-5U chassis includes a fan baffle for cooling the modules. The fan baffle makes the chassis 5 rack units (RU) high even though the modules are 4 RU high. You can mount the chassis into an EIA-standard, 19-inch (48.26 cm) rack.

For redundancy, you can use the optional 1 RU high external power supply (EPS5000-300). It provides redundant power for up to two fully populated RK5000PS-5U chassis and can be mounted into a rack.

The internal power supply has a relay output connector that is directly wired to the power and is a normally closed (N.C.) dry contact. If the power supply fails, the relay opens.

FRONT VIEW

- ❶ Fan Baffle
- ❷ Rack Ear (2)
- ❸ Power Supply with Handle
- ❹ Module Slot (12)

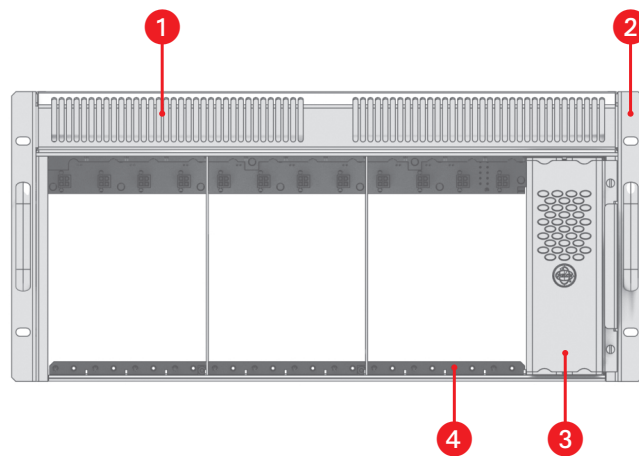

Figure 2. RK5000PS-5U Front View

BACK VIEW

- ① Thumbscrew for Fastening Modules (12)
- ② Fan (10)
- ③ 10-Pin Power Connector
- ④ Relay Output Connector
- ⑤ AC Power Cord Connector
- ⑥ Power Switch
- ⑦ Spare Fuse

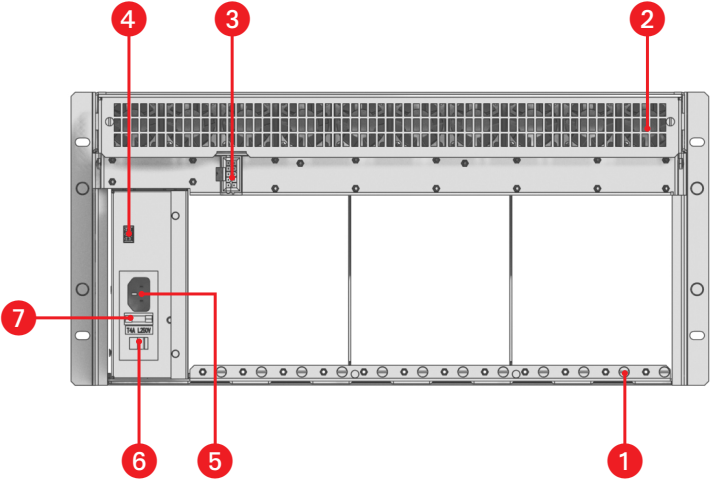

Figure 3. RK5000PS-5U Back View

Installation

MOUNTING A CHASSIS

The RK5000PS-5U chassis can be mounted into an EIA-standard, 19-inch rack. To mount the chassis into a rack, follow these steps and refer to Figure 4.

1. Insert the chassis into the rack.
2. Secure the chassis to the rack with the supplied screws and washers.

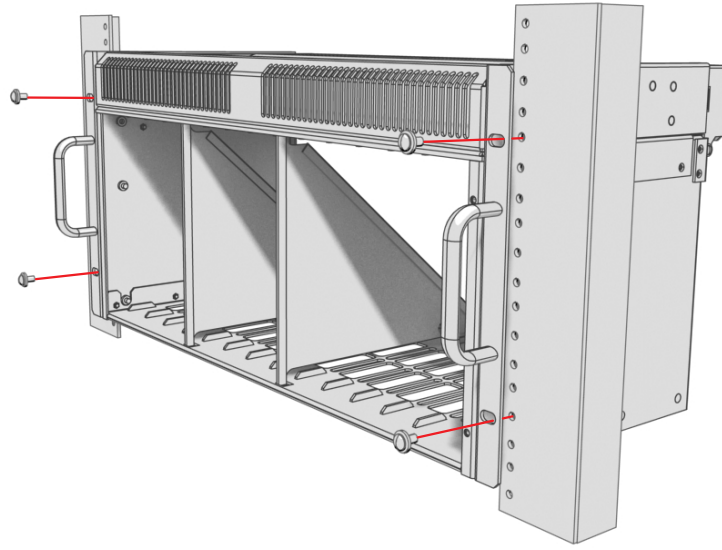

Figure 4. Mounting an RK5000PS-5U into a Rack

If installing the RK5000PS-5U into a square-hole rack, insert two cage nuts in each side of the square-hole rack as shown in Figure 5.

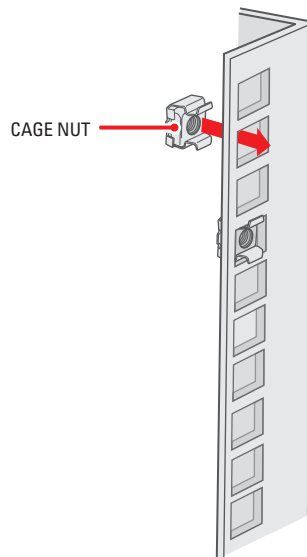

Figure 5. Inserting Cage Nuts

INSTALLING A MODULE

You can install up to 12 single-width modules into the RK5000PS-5U. To install a module, follow these steps and refer to Figure 6.

1. Insert the module into an empty slot of the chassis. The two slots on the right are for the power supply.
2. Secure the module by tightening the thumbscrew on the back of the chassis.

NOTE: Some versions of the Endura module do not have a threaded screw hole for the thumbscrew in the primary threaded standoff to engage. If the threaded screw hole aligns with the secondary standoff, use one of the supplied thumbscrews.

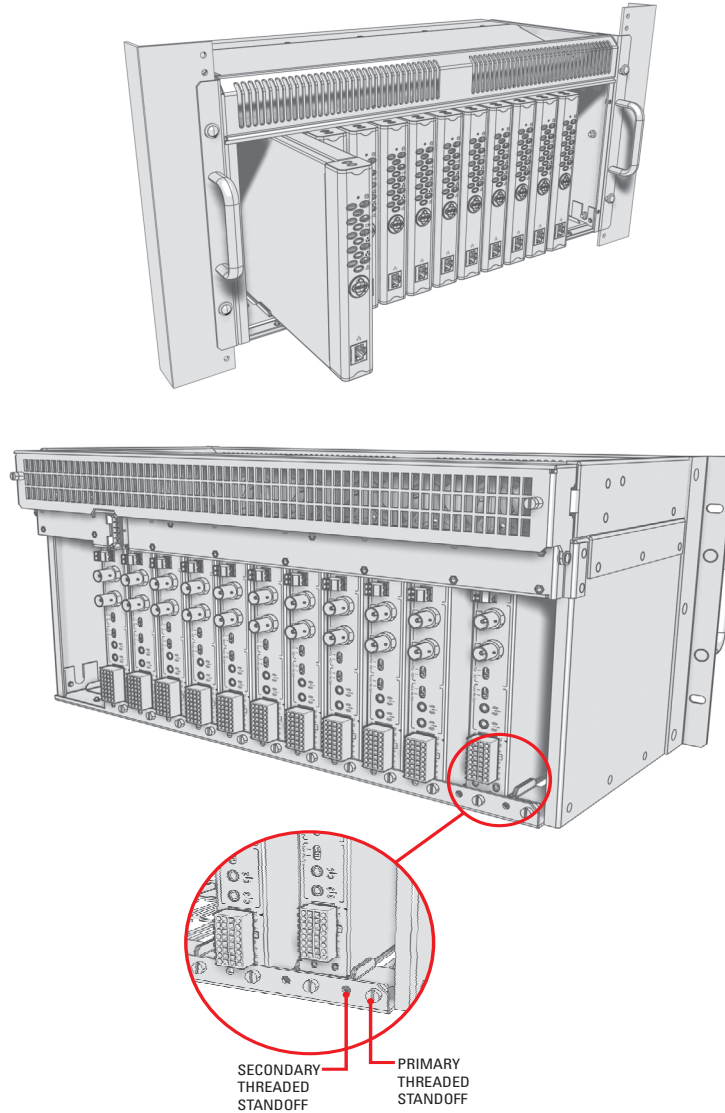

Figure 6. Endura IP System Module Installation

INSTALLING A BLANK MODULE

Single-width blank modules can be used to fill the empty module slots on the chassis. To install a blank module, follow these steps and refer to Figure 7.

1. Insert the blank module into the empty slot on the chassis.
2. Secure the blank module by tightening the thumbscrew on the back of the chassis.

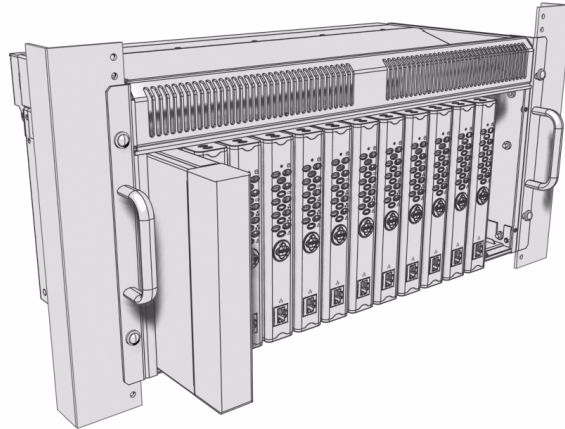

Figure 7. Blank Module Installation

INSTALLING AN INTERNAL POWER SUPPLY

The double-width internal power supply must be installed into the RK5000PS-5U chassis. To install the internal power supply, follow these steps and refer to Figure 8.

1. Insert the power supply into the rack.
2. Secure the power supply by tightening the two thumbscrews on the front of the chassis.
3. Plug in the power cord.
4. Turn on the power supply.

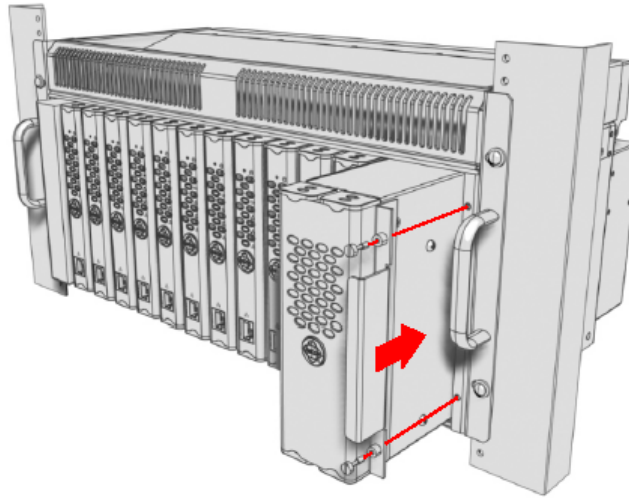

Figure 8. Power Supply Installation

Service

REPLACING AN INTERNAL POWER SUPPLY

You can easily replace the internal power supply in the RK5000PS-5U with a replacement (RK5PWR-300). You will know if there is a problem with the power supply because the blue Pelco badge on the front panel will turn off. Before replacing the power supply, check the fuse. It can be replaced easily with the supplied spare. If the fuse is not the problem, then follow these steps and refer to Figure 8 to replace the power supply.

1. Unplug the AC power cord.
2. Unscrew the two thumbscrews on the front of the chassis that hold the power supply.
3. Pull the power supply out of the chassis using the handle.
4. Insert the new power supply.
5. Secure the power supply by tightening the two thumbscrews on the front of the chassis.
6. Plug in the AC power cord.
7. Turn on the power switch.

REPLACING A FAN

The fan baffle on the RK5000PS-5U has 10 fans. These fans can be replaced easily in case of failure. To replace a fan, follow these steps and refer to Figures 9-12.

1. Unscrew the two thumbscrews on the back of the fan baffle.
2. Lower the back panel until the fans are exposed.
3. Unscrew the two screws that hold the fan in place.
4. Unplug the red 2-pin connector from the bus board.
5. Remove the failed fan and insert the new one.
6. Plug in the 2-pin connector.
7. Tighten the two screws to hold the fan in place.

⚠ WARNING: Do not overtighten the two screws. Doing so can crack the plastic fan case.

8. Raise the back panel and tighten both thumbscrews.

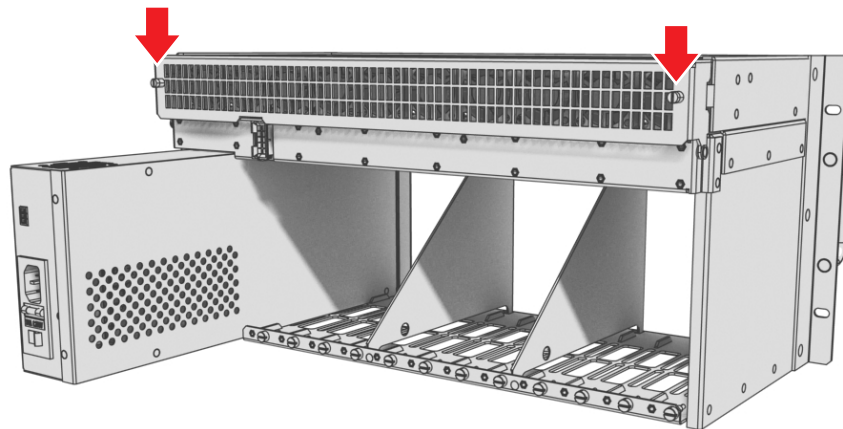

Figure 9. Fan Baffle Thumbscrews

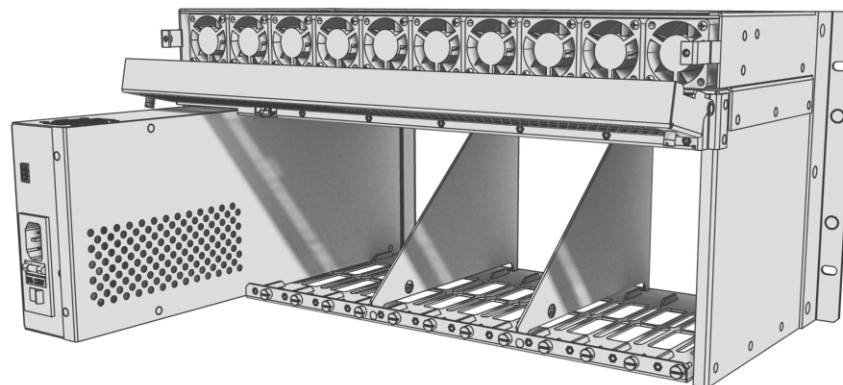

Figure 10. Fan Baffle Back Panel

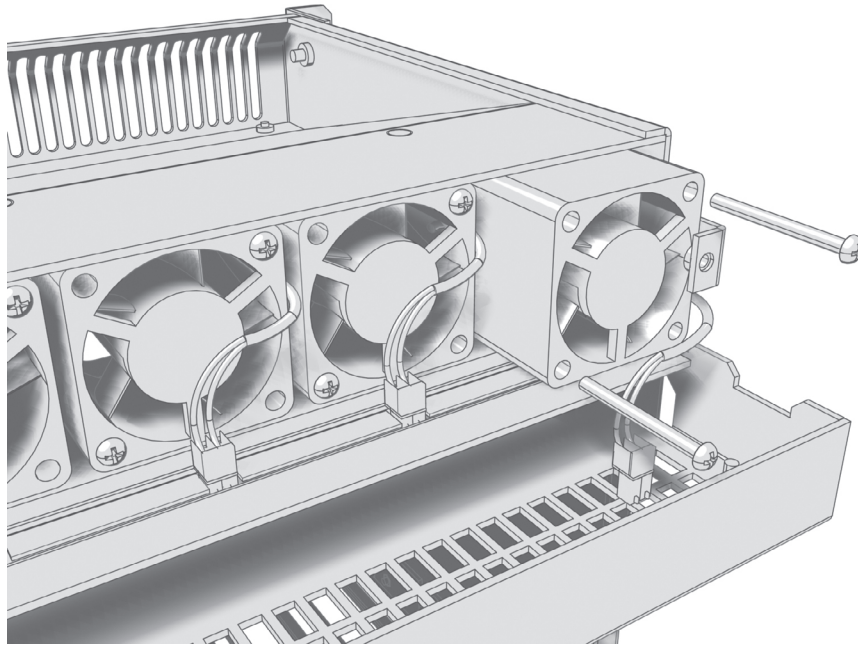

Figure 11. Fan Screws

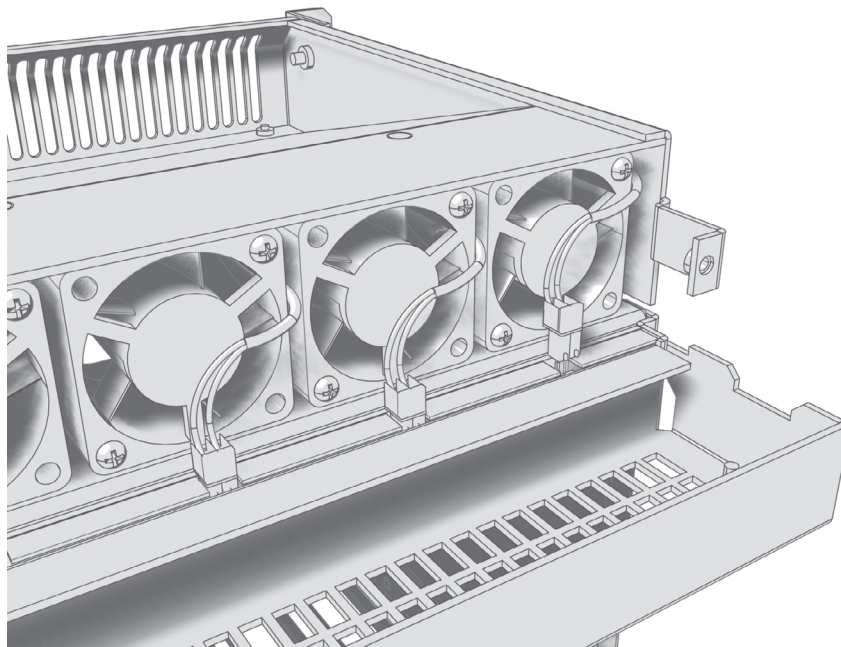

Figure 12. Fan Connector

Specifications

ELECTRICAL

Input Voltage	100-240 VAC, 50-60 Hz, autoranging
Output Voltage	12 VDC
Power Consumption	Operating Maximum (non-inclusive of components within the rack)
100 VAC	110 W, 454 BTU/H
115 VAC	115 W, 471 BTU/H
220 VAC	220 W, 492 BTU/H
Fuse	4 amps/250 V
Redundant Capability	Yes with optional EPS5000-300 power supply

MECHANICAL

Number of Slots	12 for modules and 2 for power supply
Module Orientation	Vertical
Rack Units	5 (includes fan baffle)
Construction	Aluminum
Finish	Black

ENVIRONMENTAL

Ambient Temperature	70° to 74°F (21° to 23°C)
Operating Temperature	32° to 122°F (0° to 50°C) at air intake of unit
Storage Temperature	-40° to 149°F (-40° to 65°C)
Operating Humidity	20% to 80% noncondensing
Maximum Humidity	Gradient 10% per hour
Operating Altitude	-50 ft to 10,000 ft (-16 m to 3,048 m)
Operating Vibration	0.25 G at 3 Hz to 200 Hz at a sweep rate of 0.5 octaves/minute

GENERAL

Dimensions	8.72" H x 17.70" W x 15.50" D (22.15 x 44.96 x 39.37 cm)
Mounting	Fits 19-inch, EIA-standard rack
Unit Weight	12.7 lb (5.76 kg), with power supply 37.8 lb (17.15 kg), fully populated

PRODUCT WARRANTY AND RETURN INFORMATION

WARRANTY

Pelco will repair or replace, without charge, any merchandise proved defective in material or workmanship **for a period of one year** after the date of shipment.

Exceptions to this warranty are as noted below:

- Five years on FR/FT/FS Series fiber optic products and TW3000 Series unshielded twisted pair transmission products.
- Three years on Genex® Series products (multiplexers, server, and keyboard).
- Three years on Camclosure® and fixed camera models, except the CC3701H-2, CC3701H-2X, CC3751H-2, CC3651H-2X, MC3651H-2, and MC3651H-2X camera models, which have a five-year warranty.
- Three years on PMCL200/300/400 Series LCD monitors.
- Two years on standard motorized or fixed focal length lenses.
- Two years on Legacy®, CM6700/CM6800/CM9700 Series matrix, and DF5/DF8 Series fixed dome products.
- Two years on Spectra®, Esprit®, ExSite™, and PS20 scanners, including when used in continuous motion applications.
- Two years on Esprit and WW5700 Series window wiper (excluding wiper blades).
- Two years (except lamp and color wheel) on Digital Light Processing (DLP®) displays. The lamp and color wheel will be covered for a period of 90 days. The air filter is not covered under warranty.
- Eighteen months on DX Series digital video recorders, NVR300 Series network video recorders, and Endura™ Series distributed network-based video products.
- One year (except video heads) on video cassette recorders (VCRs). Video heads will be covered for a period of six months.
- Six months on all pan and tilts, scanners or preset lenses used in continuous motion applications (that is, preset scan, tour and auto scan modes).

Pelco will warrant all replacement parts and repairs for 90 days from the date of Pelco shipment. All goods requiring warranty repair shall be sent freight prepaid to Pelco, Clovis, California. Repairs made necessary by reason of misuse, alteration, normal wear, or accident are not covered under this warranty.

Pelco assumes no risk and shall be subject to no liability for damages or loss resulting from the specific use or application made of the Products. Pelco's liability for any claim, whether based on breach of contract, negligence, infringement of any rights of any party or product liability, relating to the Products shall not exceed the price paid by the Dealer to Pelco for such Products. In no event will Pelco be liable for any special, incidental or consequential damages (including loss of use, loss of profit and claims of third parties) however caused, whether by the negligence of Pelco or otherwise.

The above warranty provides the Dealer with specific legal rights. The Dealer may also have additional rights, which are subject to variation from state to state.

If a warranty repair is required, the Dealer must contact Pelco at (800)289-9100 or (559) 292-1981 to obtain a Repair Authorization number (RA), and provide the following information:

1. Model and serial number
2. Date of shipment, P.O. number, Sales Order number, or Pelco invoice number
3. Details of the defect or problem

If there is a dispute regarding the warranty of a product which does not fall under the warranty conditions stated above, please include a written explanation with the product when returned.

Method of return shipment shall be the same or equal to the method by which the item was received by Pelco.

RETURNS

In order to expedite parts returned to the factory for repair or credit, please call the factory at (800) 289-9100 or (559) 292-1981 to obtain an authorization number (CA number if returned for credit, and RA number if returned for repair).

All merchandise returned for credit may be subject to a 20% restocking and refurbishing charge.

Goods returned for repair or credit should be clearly identified with the assigned CA or RA number and freight should be prepaid. Ship to the appropriate address below.

If you are located within the continental U.S., Alaska, Hawaii or Puerto Rico, send goods to:

Service Department
Pelco
3500 Pelco Way
Clovis, CA 93612-5699

If you are located outside the continental U.S., Alaska, Hawaii or Puerto Rico and are instructed to return goods to the USA, you may do one of the following:

If the goods are to be sent by a COURIER SERVICE, send the goods to:

Pelco
3500 Pelco Way
Clovis, CA 93612-5699 USA

If the goods are to be sent by a FREIGHT FORWARDER, send the goods to:

Pelco c/o Expeditors
473 Eccles Avenue
South San Francisco, CA 94080 USA
Phone: 650-737-1700
Fax: 650-737-0933

 The materials used in the manufacture of this document and its components are compliant to the requirements of Directive 2002/95/EC.



This equipment contains electrical or electronic components that must be recycled properly to comply with Directive 2002/96/EC of the European Union regarding the disposal of waste electrical and electronic equipment (WEEE). Contact your local dealer for procedures for recycling this equipment.

REVISION HISTORY

Manual #	Date	Comments
C1615M	4/05	Original version.
C1615M-A	9/05	Added <i>Before You Begin</i> section. Added Figure 5. Revised Power Consumption in <i>Specifications</i> .
C1615M-B	1/06	Revised rack illustrations to show two shelf dividers.
C1615M-C	9/06	Revised specifications.

Pelco, the Pelco logo, Spectra, Genex, Esprit, Camclosure, and Legacy are registered trademarks of Pelco.
Endura and ExSite are trademarks of Pelco.
DLP is a registered trademark of Texas Instruments, Inc.

© Copyright 2006, Pelco. All rights reserved.



Worldwide Headquarters
3500 Pelco Way
Clovis, California 93612 USA

USA & Canada
Tel: 800/289-9100
Fax: 800/289-9150

International
Tel: 1-559/292-1981
Fax: 1-559/348-1120

www.pelco.com

ISO9001